

RECEPTIUA

DS DELUXE
SYSTEMS
ITALIAN WINDOWS CULTURE

FLESSYA®

RECEPTIVA

La soluzione
su misura per
il tuo progetto
alberghiero

*The custom solution for
your hospitality project*

Sicure contro il fuoco

Fire
safety

La linea Receptiva è prodotta con tecniche all'avanguardia garantendo i massimi livelli di protezione antincendio.

Ogni porta è stata costruita con materiali sicuri e ignifughi, aggiungendo l'estetica e l'eleganza delle forme e delle essenze. È certificata e omologata in classe EI 30 e EI 60 secondo quanto stabilito dalla nuova normativa Europea UNI EN 1634-1.

The Receptiva line is manufactured using cutting-edge technology to guarantee maximum fire protection levels.

Each door is constructed with safe fireproof materials, adding elegance to the shape and wood.

It is Class EI 30 and EI 60 certified and approved according to the new European standard UNI EN 1634-1



Resistenza al fuoco 30 minuti
Fire resistance 30 minutes



Resistenza al fuoco 60 minuti
Fire resistance 60 minutes



Silenziose contro i rumori

Abbiamo costruito l'intera linea scegliendo i migliori materiali insonorizzanti che permettono di garantire privacy e riposo agli ospiti. I materiali fonoisolanti utilizzati, consentono di evitare che i rumori esterni alla stanza siano di disturbo alla quiete interna. Sono certificate e omologate con abbattimento acustico 26 db - 31 db per i modelli EI 30 e 32 db - 37 db - 41 db per quelli EI 60, secondo la norma UNI EN 1634-1.

*Quiet against
noise*

We have built the entire line by selecting the best soundproofing materials that guarantee guests' privacy and rest. The soundproofing materials used avoid that noises outside the room disturb the interior peace. They are certified and approved with 26 db - 31 db noise reduction for EI 30 models and 32 db - 37 db - 41 db for EI 60 models, according to UNI EN 1634-1 regulations.



Fono isolamento 26/31 db
Sound insulation 26/31 db



Fono isolamento 32/37/41 db
Sound insulation 32/37/41 db



Si adatta ai tuoi progetti

*They adapt
to your project*

La linea Receptiva porterà il tuo progetto a diventare un hotel sicuro con porte qualitativamente superiori, resistenti al fuoco e ai rumori esterni.

The Receptiva line will take your project to the next level, making your hotel safe with superior quality, fire resistant and sound-resistant doors.

Colori, finiture, materiali e dimensioni

*Colours, finishes,
materials and dimensions*

Si adatteranno ai tuoi ambienti arricchendo la qualità della struttura.

*Adapt to your space,
enriching the quality
of your facility.*

Incisioni

Engravings

INCISO

Incisione classica a "V" dallo stile minimale, perfetta per chi vuole una porta lavorata senza rinunciare alla semplicità. Oltre ai 17 modelli di listino, è possibile realizzare disegni su richiesta.

RIGA

Intrigante evoluzione della classica pantografatura: un'incisione squadrata, piatta, elegante nella sua linearità. Oltre ai 14 modelli di listino, è possibile realizzare disegni su richiesta.

SFIORO

Un'incisione dallo stile moderno, un tocco eccentrico per chi ama distinguersi e cerca sempre nuove soluzioni di design. Oltre ai 6 modelli di listino, è possibile realizzare disegni su richiesta.

ENGRAVED

Classic engraving minimal "V"-style, perfect for those who want a door worked without sacrificing simplicity. In addition to the 17 models of the list, you can make drawings by request.

STRIPE

Intriguing evolution of the classic routing: square incision, flat and elegant in its linearity. In addition to the 14 models in the list, you can make designs on request.

RELIEF

An incision with a contemporary style, an eccentric touch for those who love to stand out and always try new design solutions. In addition to the 6 models of the list, you can make designs on request.

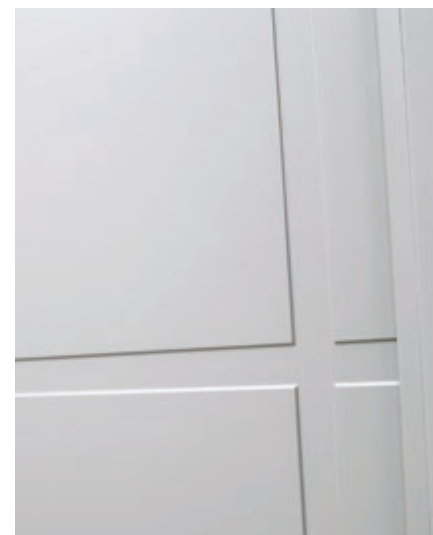

Pantografatura

Pantographing

PANTOGRAFATURA CLASSICA

Valorizza lo spessore e la qualità del legno. La pantografatura classica richiama l'estetica della bugna e può essere realizzata con angoli dritti oppure arrotondati. Possibilità di personalizzazione con disegni forniti dal cliente.

PANTOGRAFATURA STRETTA

Una lavorazione che arricchisce l'estetica della porta senza appesantirla, creando un gioco di luce molto raffinato. Uno stile ricco, una soluzione insolita e originale. Possibilità di personalizzazione con disegni forniti dal cliente.

PANTOGRAFATURA QUADRA

Pantografatura in stile moderno: un doppio disegno squadrato e regolare sfrutta i volumi e lo spessore del legno per creare insoliti giochi di luce. Massima definizione stilistica. Possibilità di personalizzazione con disegni forniti dal cliente.

CLASSICAL PANTOGRAPHING

It enhances the thickness and the quality of the wood. The classical pantographing invoke the aesthetics of the boss and can be realized with straight or rounded corners. We can customize with designs provided by customers.

NARROW PANTOGRAPHING

A process that enhances the look of the door without weighing it down, by creating a very refined play of light. A rich style, an unusual and original solution. We can customize with designs provided by customers.

SQUARE PANTOGRAPHING

A modern style of pantographing: a double square and regular design takes advantages of the volumes and the thickness of the wood in order to create unusual play of lights. Maximum stylistic definition. We can customize with designs provided by customers.





423

422

421

12_13

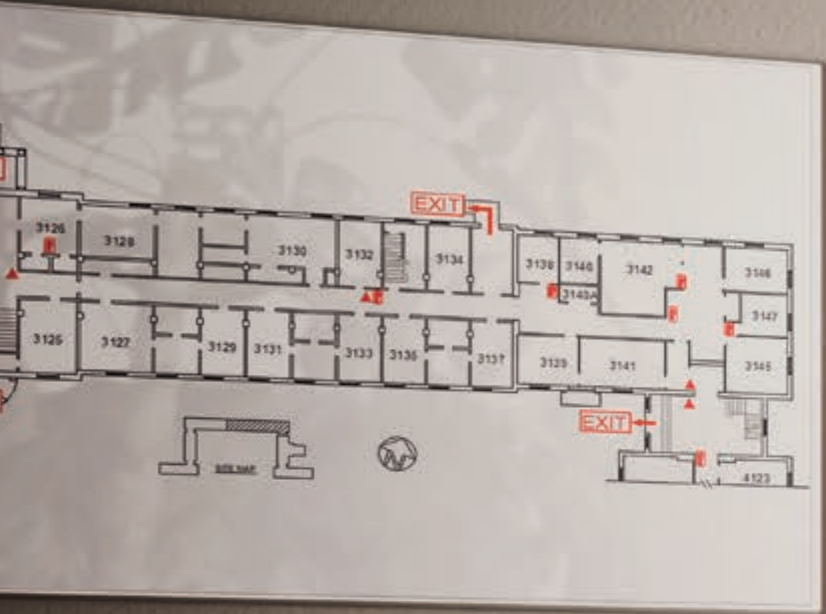

8

7

TQ30
ivory lacquered ral 1013 / laccato avorio ral 1013
lineo frame ampia walled frame / telaio lineo cornice ampia



30  **TS20F**
26  laccato grigio 0238 / *grey lacquered 0238*
telaiο lineo cornice unghiata con basette e capitello A / *grooved casing lineo doorframe with baseplate and "A" head*





19

20



21

22

20_21



145



30  NR30
31  laccato tortora ral 1019 / *dove lacquered ral 1019*
telaio lineo cornice ampia / *lineo frame ampia walled frame*



147

NR15
black open-pored lacquered ash ral 9005 / frassino laccato poro aperto nero ral 9005
lineo frame smooth surface lacquered plana walled frame / telaio lineo laccato liscio cornice plana



60  **NS05**
39  laccato grigio antracite ral 9016 / charcoal grey lacquered ral 9016
telaiio lineo cornice plana / lineo frame plana walled frame

24_25



326

320

322

SUITES
320 - 329
→
SUITES
310 - 319
←

epoca ash ivory ral 1013 / frassino epoca avorio ral 1013
lineo frame recta walled frame / telaio lineo cornice recta

n05

30

26

26_29



chiudiporta con braccio a V / overhead door closer with V arm



overhead door closer with sliding arm / chiudiporta con braccio a slitta

chiudiporta a scomparsa / concealed overhead door closer



disappearing spring door closer / chiudiporta con molla a scomparsa



modelli incisi *engraved models*



mod. N13 mod. N14 mod. N15 mod. N16 mod. N17 mod. N18 mod. N19 mod. N20



mod. N21 mod. N22 mod. N23 mod. N24 mod. N25 mod. N26 mod. N27 mod. N28

modelli inserti alluminio stondati *models with rounded aluminium inserts*



mod. NI00 mod. NI01 mod. NI02 mod. NI03 mod. NI04

full models modelli con pantografatura standard



mod. T00 mod. T01 mod. T02 mod. T03 mod. T04 mod. T20 mod. T21 mod. T22



mod. T23 mod. T24 mod. T25 mod. T26 mod. T30 mod. T31 mod. T32 mod. T33



mod. T34 mod. T40 mod. T41 mod. T42 mod. T43

modelli riga *riga models*



mod. NR00 mod. NR10 mod. NR11 mod. NR12 mod. NR13 mod. NR14 mod. NR20 mod. NR26



mod. NR30 mod. NR31 mod. NR40 mod. NR41 mod. NR42 mod. NR43

modelli inserti alluminio passanti *models with pass-through aluminium inserts*



mod. N01D mod. N01 mod. N02 mod. N03 mod. N04

sfiato models modelli sfiato



mod. NS00 mod. NS01 mod. NS02 mod. NS03 mod. NS04 mod. NS05

slim profile models modelli con pantografatura con sagoma stretta



mod. TS15 mod. TS18 mod. TS20F mod. TS30F mod. TS40F

quadra models modelli con pantografatura quadra



mod. TQ00 mod. TQ20 mod. TQ26 mod. TQ30 mod. TQ31 mod. TQ40 mod. TQ41 mod. TQ42 mod. TQ43

standard *standard*



ral 1013 ral 9001 ral 9010 ral 9016

base *basic*

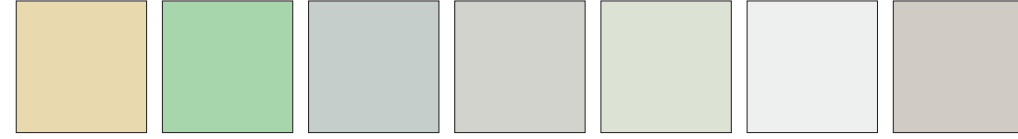

ral 1015 ral 6019 ral 7035 ral 7047 ral 9002 ral 9003 ica 0238

extra *extra*

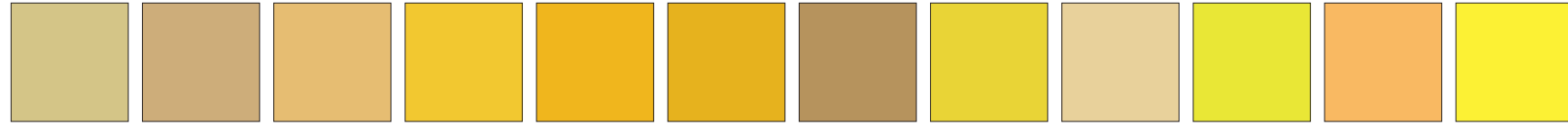

ral 1000 ral 1001 ral 1002 ral 1003 ral 1004 ral 1005 ral 1011 ral 1012 ral 1014 ral 1016 ral 1017 ral 1018

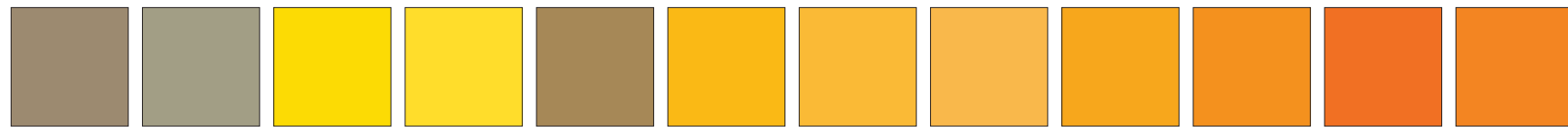

ral 1019 ral 1020 ral 1021 ral 1023 ral 1024 ral 1028 ral 1033 ral 1034 ral 1037 ral 2003 ral 2004 ral 2008



ral 2009 ral 2010 ral 2011 ral 2012 ral 3000 ral 3001 ral 3002 ral 3003 ral 3004 ral 3005 ral 3007 ral 3009



ral 3011 ral 3012 ral 3013 ral 3014 ral 3015 ral 3016 ral 3017 ral 3018 ral 3020 ral 3022 ral 3027 ral 3031



ral 4001 ral 4002 ral 4003 ral 4004 ral 4005 ral 4006 ral 4007 ral 4008 ral 4009 ral 4010 ral 5000 ral 5001



ral 5002 ral 5003 ral 5004 ral 5007 ral 5008 ral 5009 ral 5010 ral 5011 ral 5012 ral 5013 ral 5014 ral 5015



ral 5017 ral 5018 ral 5019 ral 5020 ral 5021 ral 5022 ral 5023 ral 5024 ral 6000 ral 6001 ral 6002 ral 6003



ral 6004 ral 6005 ral 6006 ral 6007 ral 6008 ral 6009 ral 6010 ral 6011 ral 6012 ral 6013 ral 6014 ral 6015



ral 6016 ral 6017 ral 6018 ral 6020 ral 6021 ral 6022 ral 6024 ral 6025 ral 6026 ral 6027 ral 6028 ral 6029

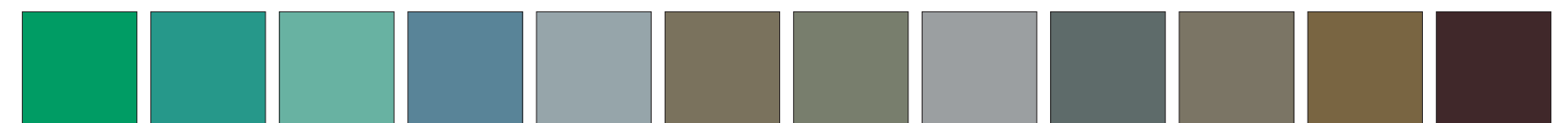

ral 6032 ral 6033 ral 6034 ral 7000 ral 7001 ral 7002 ral 7003 ral 7004 ral 7005 ral 7006 ral 7008 ral 7009



ral 7010 ral 7011 ral 7012 ral 7013 ral 7015 ral 7016 ral 7021 ral 7022 ral 7023 ral 7024 ral 7026 ral 7030

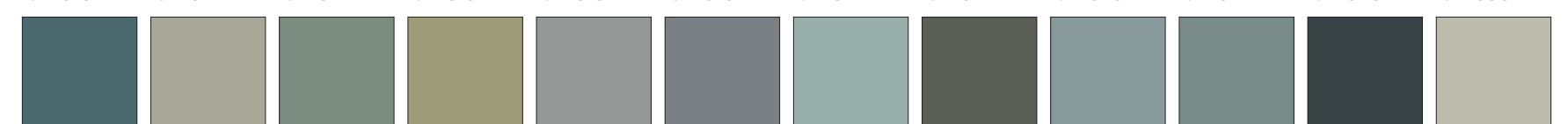

ral 7031 ral 7032 ral 7033 ral 7034 ral 7036 ral 7037 ral 7038 ral 7039 ral 7040 ral 7042 ral 7043 ral 7044



ral 8007 ral 8008 ral 8011 ral 8012 ral 8014 ral 8015 ral 8016 ral 9004 ral 9005 ral 9006 ral 9007 ral 9018

poro aperto *open pore*



frassino laccato poro aperto *lacquered ash open pore* frassino epoca *epoca ash* pino laccato a poro aperto *lacquered pine open pore*

tutti i colori ral o di altra mazzetta analoga sono riproducibili nelle finiture laccate *all ral colors or analogous are reproducible in lacquered finishes*
i colori ral riportati sono puramente indicativi *the brought ral colors are purely indicative*

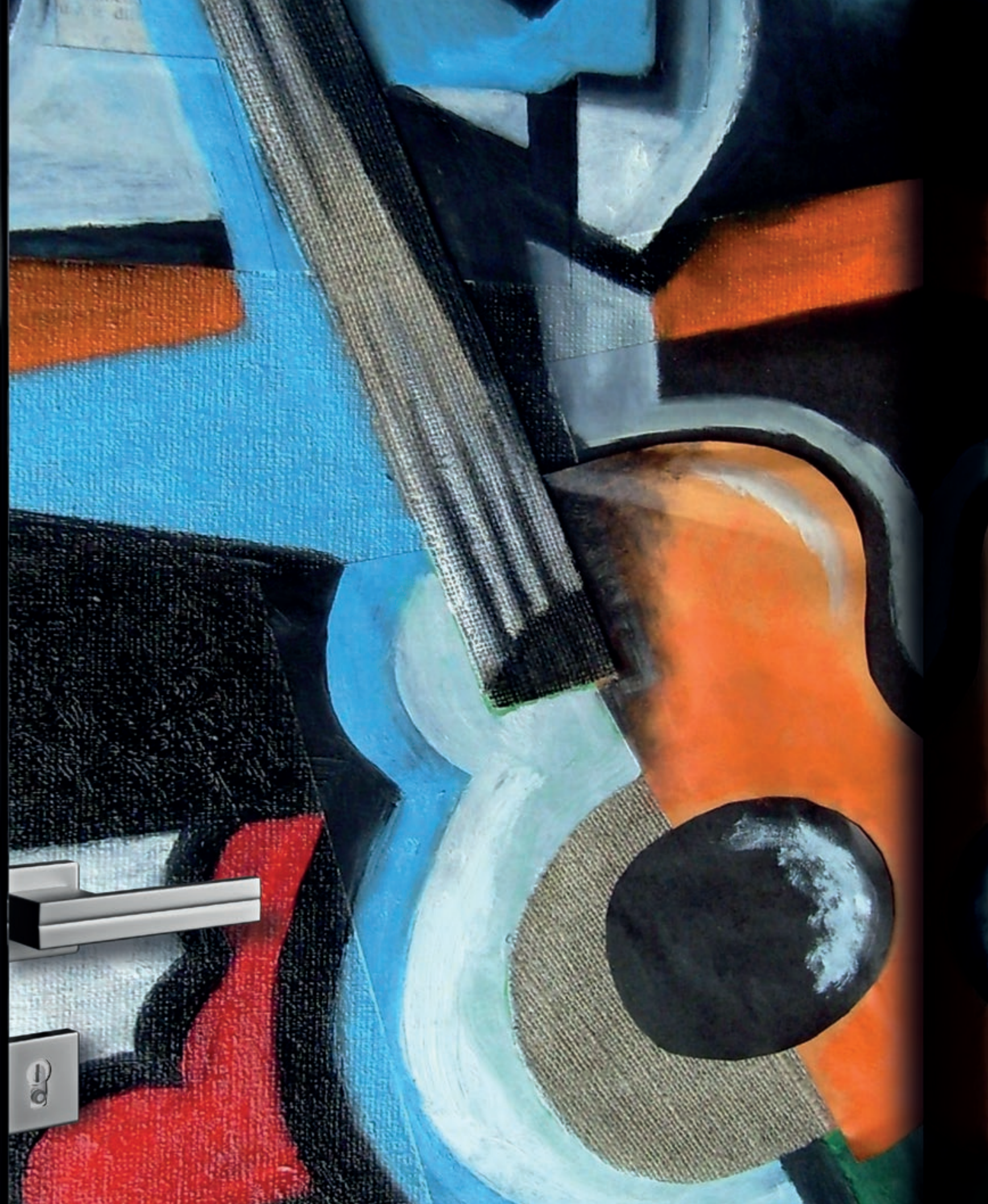

Stampa digitale

Digital printing

"Flessy-art" è l'esclusiva tecnica a stampa digitale che permette di personalizzare le porte oltre ogni immaginazione, con immagini proprie oppure selezionate dalle nostre banche dati. Qualità fotografica eccezionale per un risultato nitido e brillante: la stampa, coprente o semi-trasparente, può essere applicata sia alle ante verniciate sia a quelle in legno naturale e garantisce ottime performance di durata.

"Flessy-art" is the exclusive digital printing technique that allows you to customize doors beyond imagination, with your own pictures or selected from our databases. Exceptional photo quality for a clear and bright result: the printing or semi-transparent wrap, can be applied both to the painted doors and to those in natural wood and ensures optimal performance and durability.

Caratteristiche tecniche:

Risoluzione minima immagine: 300dpi.

Consigli di manutenzione: è sufficiente pulire con un panno inumidito.

Specifications:

Minimum image resolution: 300dpi.

Maintenance advices: simply wipe with a humid cloth.

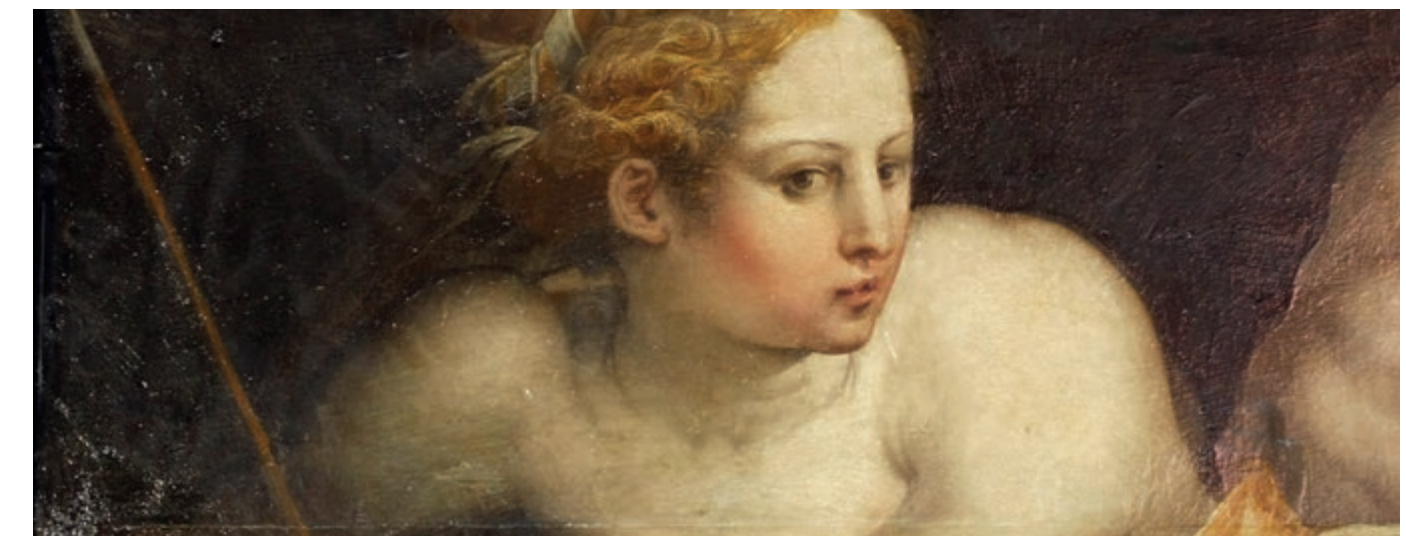



city



klimt

graphic

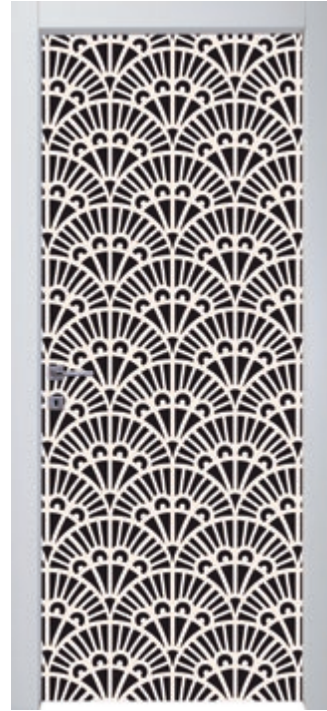

illusion

fumo



font

floreal



wallpaper

seta

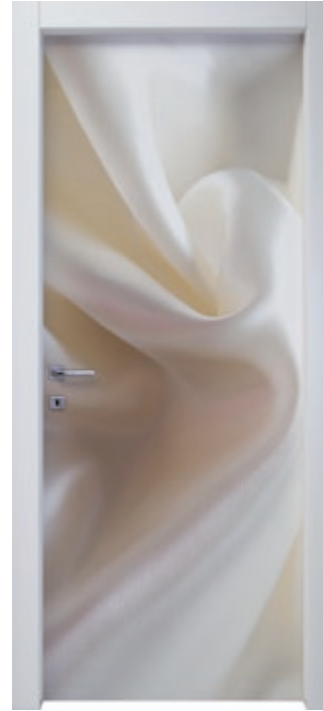

astratto

poetry

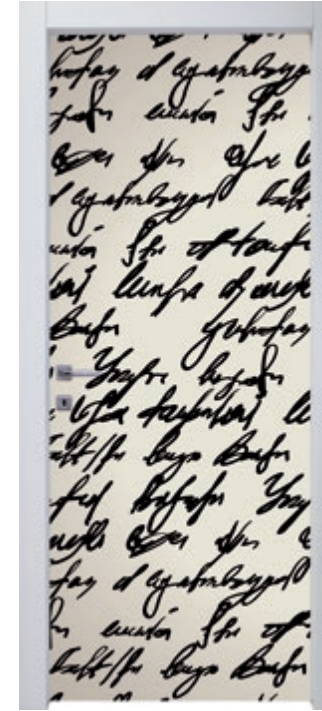

graffiti

fiori



tramonto

luna

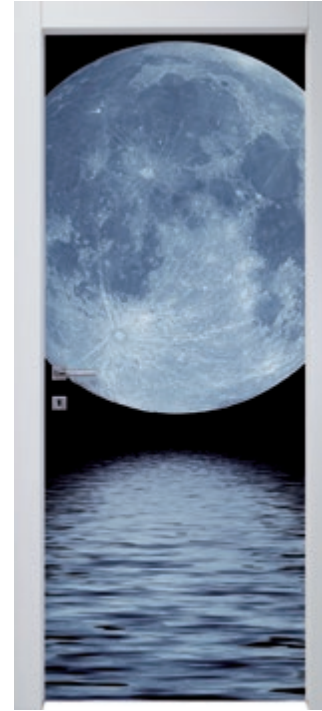

optical

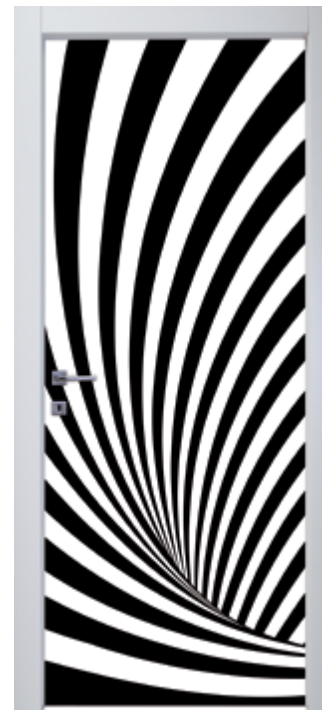
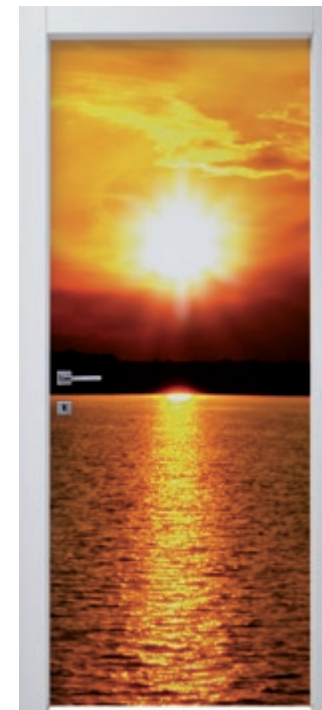
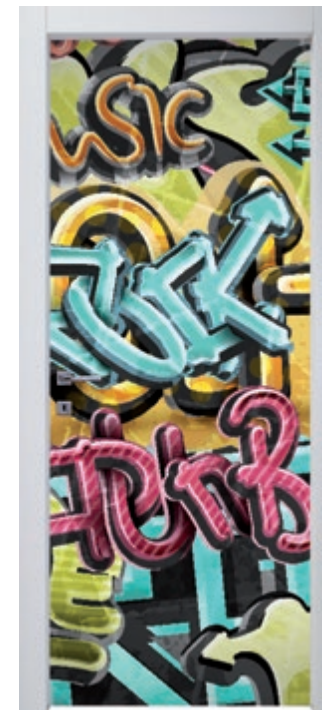
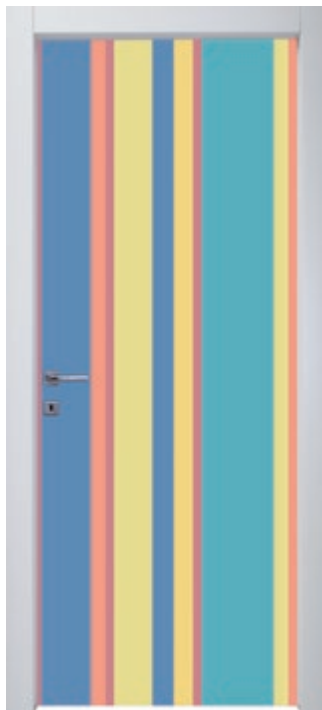
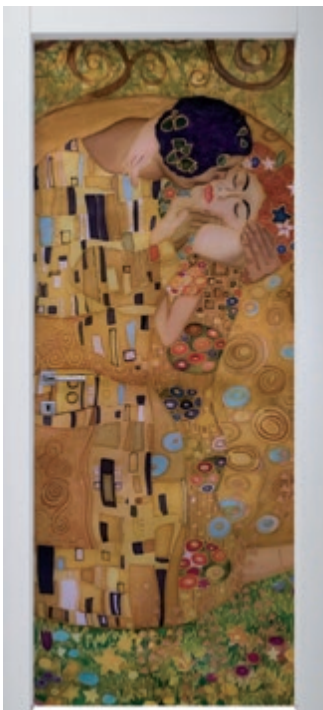



Legno

Wood

Le migliori essenze in legno, con molteplici varianti di colore, sono state scelte per adattarsi allo stile del tuo hotel. Ogni porta potrà essere lavorata in modo da rendere vive le venature, i colori e la porosità, senza perdere il naturale calore del legno.

La sicurezza abbraccia lo stile scegliendo le differenti incisioni o gli intarsi con diverse essenze.

The best wood, in many colours, have been selected to adapt to your hotel style. Each door can be worked to bring out the veins, colours, and pores, without forgoing the natural warmth of the wood.

Safety embraces style, choosing different carvings or inlays in different woods.

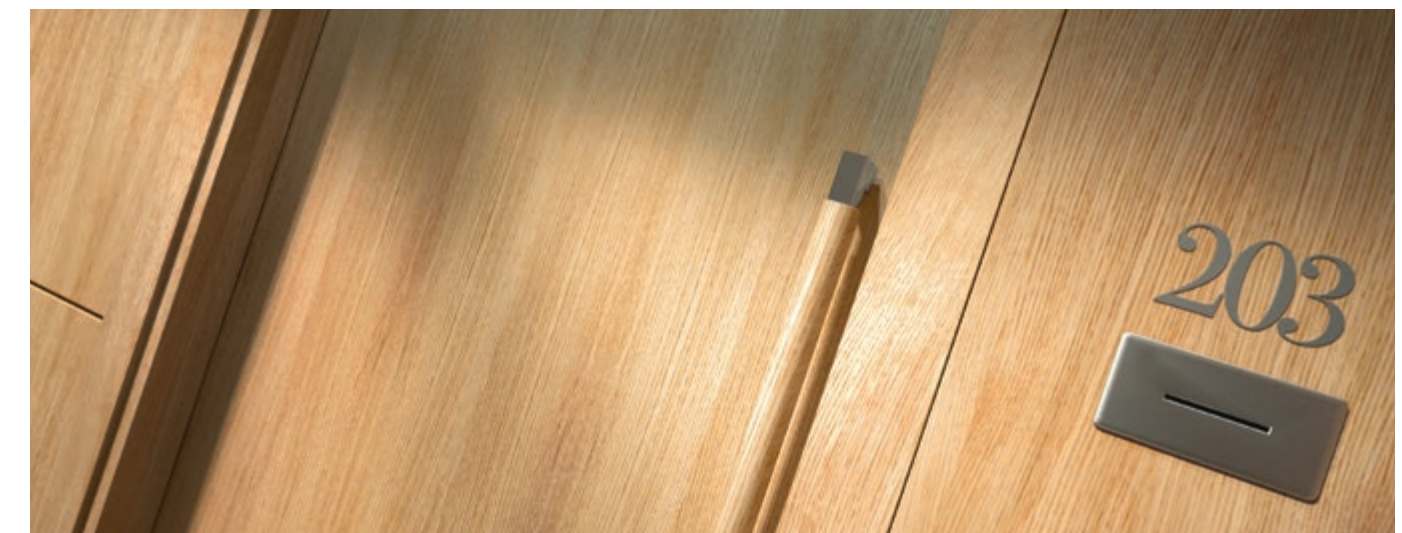





401

402

403

44_45



30  **n06**
31  pino antico / antique pine
telaio lineo cornice recta / lineo frame recta walled frame



n06  30
antique pine / pino antico
lineo frame recta walled frame / telaio lineo cornice recta  31



48_49

modelli intarsiati *inlaid models*



mod. N05 mod. N06 mod. N07 mod. N08 mod. N09 mod. N10 mod. N11 mod. N12

models with rounded aluminium inserts modelli inserti alluminio stondati



mod. NI00 mod. NI01 mod. NI02 mod. NI03 mod. NI04



modelli incisi engraved models



mod. N13 mod. N14 mod. N15 mod. N16 mod. N17 mod. N18 mod. N19 mod. N20

models with pass-through aluminium inserts modelli inserti alluminio passanti



mod. N01D mod. N01 mod. N02 mod. N03 mod. N04



mod. N21 mod. N22 mod. N23 mod. N24 mod. N25 mod. N26 mod. N27 mod. N28

finiture legno *wood finishes*



tanganika *tanganika*



tanganika cuoio *leather tanganika*



noce nazionale bicolore *two-coloured walnut*



noce nazionale biondo *blonde walnut*



tanganika ciliegio *cherry tanganika*



tanganika tabacco *tobacco tanganika*



pino graffiato rame *pine scratched copper*

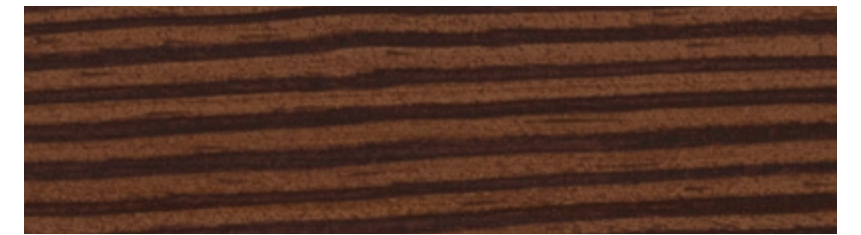

pino graffiato antico *scratched pine antique*

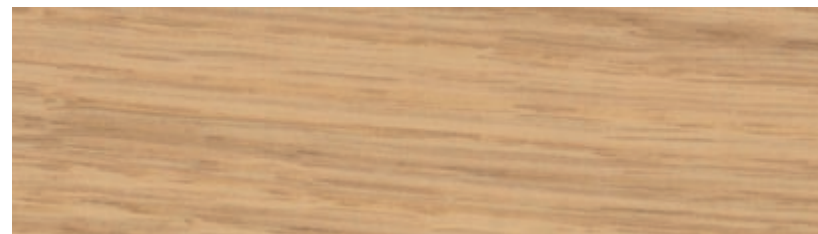

rovere *oak*

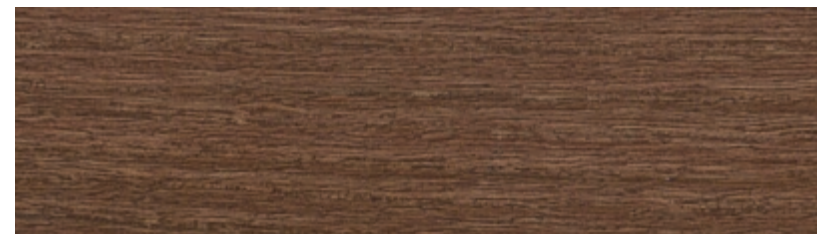

rovere tabacco *tobacco oak*

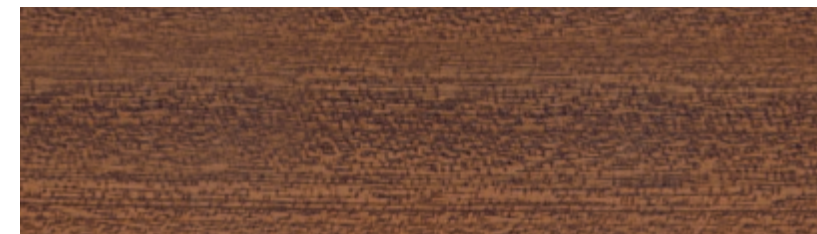

mogano *mahogany*



teak *teak*

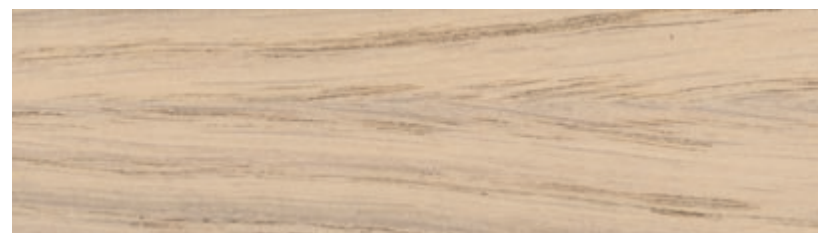

rovere sbiancato *bleached oak*

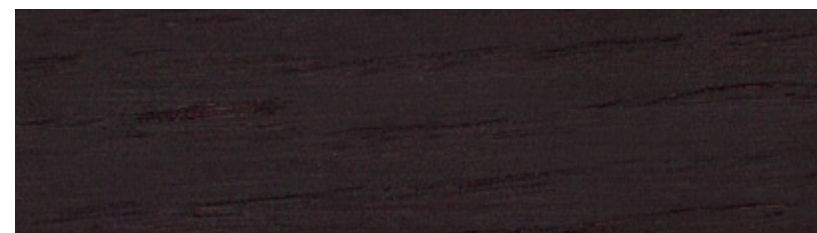

rovere caffè *coffee oak*



zebrano *zebrano*



frassino sbiancato *bleached ash*

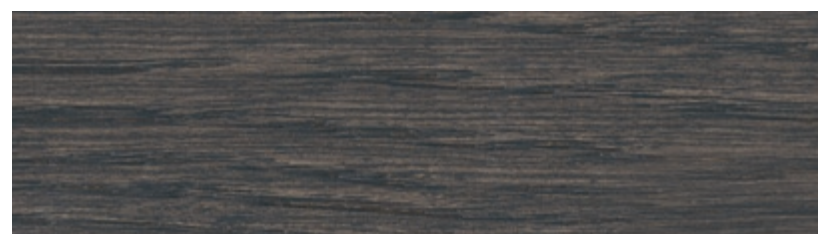

rovere grigio *grey oak*



ciliegio *cherry*



acero *maple*

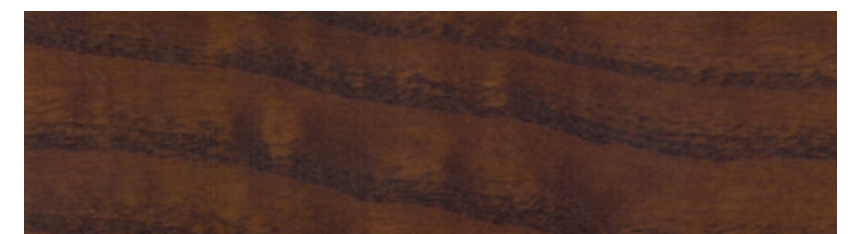

frassino antico *antique ash*



Particolari tecnici e accessori

Technical details and Accessories

Porta ei 30

Door ei 30

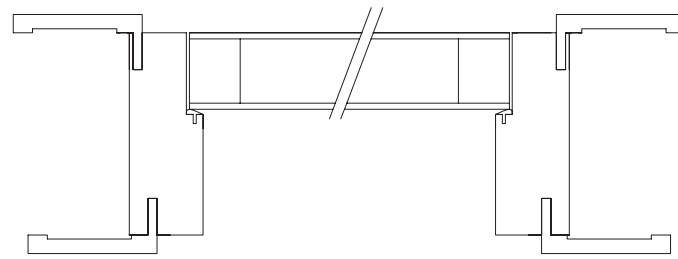

Anta: spessore 44 mm, costituita intelaiatura in abete giuntato 40x38 mm placcato con MDF sp. 5 mm, riempimento con lastra a base di fibra minerale densità 280 Kg/mc, bordi rivestiti in tranciato dell'essenza richiesta.

Telaio: listellare di abete impiallacciato o rivestito con materiale preverniciato sp. 40 mm, con cornici telescopiche in multistrato impiallacciato sezione 70x30 mm, guarnizione di battuta in gomma, guarnizione termoespandente incassata su 3 lati. Ferramenta: cerniera a scomparsa in zama e acetlica registrabile su 3 assi, rostro di tenuta, serratura yale con cilindro da 70 mm.

Door leaf: 44 mm thick, consisting of jointed fir framework 40x38 mm clad with 5 mm MDF, filled with 280 kg/cu. m mineral fibre sheets, edged in sliced veneer in the wood desired.

Doorframe: Fir blockboard 40 mm pre-coated or veneered, with telescopic frame in veneered plywood with 70x30 mm cross-section, rubber door striker seal, heat-expanding gasket sunk on 3 sides. Hardware: concealed hinges in Zamak and auxiliary resin with 3-axis adjustment, fixing bolt, 70 mm Yale cylinder lock.

Porta ei 60

Door ei 60

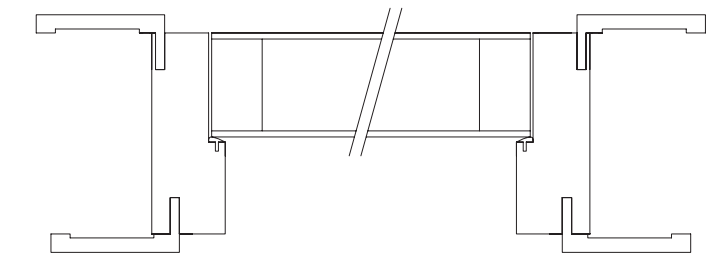

Anta: spessore 59 mm, costituita intelaiatura in rovere 40x38 mm placcato con MDF sp. 5 mm, riempimento con lastra a base di fibra minerale densità 290 Kg/mc, bordi rivestiti in tranciato dell'essenza richiesta.

Telaio: listellare di rovere impiallacciato o rivestito con materiale preverniciato sp. 40 mm, con cornici telescopiche in multistrato impiallacciato sezione 70x30 mm, guarnizione di battuta in gomma, guarnizione termoespandente incassata su 3 lati. Ferramenta: cerniere a scomparsa in zama registrabili su 3 assi, rostri di tenuta, serratura yale con cilindro da 70 mm.

Door leaf: 59 mm thick, consisting of jointed oak framework 40x38 mm clad with 5 mm MDF, filled with 290 kg/cu. m mineral fibre sheets, edged in sliced veneer in the wood desired.

Frame: Oak blockboard 40 mm pre-coated or veneered, with telescopic frame in veneered plywood with 70x30 mm cross-section, rubber door striker seal, heat-expanding gasket sunk on 3 sides. Hardware: concealed hinges in Zamak with 3-axis adjustment, fixing bolt, 70 mm Yale cylinder lock.

telaio *frame* LINEO

telaio squadrato con doppia fresata per inserimento cornici telescopiche e guarnizione di battuta
square frame with double milling for the introduction of telescopic frames and door stop gasket

lineo + recta 70x30 mm
lineo + plana 85x12 mm
lineo + curva 80x40 mm
lineo + sagoma 75x40 mm
lineo + ampia 80x30 mm
lineo + quadra 100x18 mm



cornice *walled frame* RECTA
cornice *walled frame* PLANA
cornice *walled frame* CURVA
disponibile con traverso recta
available with recta top rail
cornice *walled frame* SAGOMA
disponibile con traverso recta
available with recta top rail
cornice *walled frame* AMPIA
cornice *walled frame* QUADRA

cornice *walled frame* UNGHIATA

unghiata: 90x20 mm a chiodare
unghiata: 90x20 mm to nail



finiture: laccati, goffrati, tanganika, tanganika cuoio, tanganika ciliegio, tanganika tabacco
finishes: lacquered, embossed, tanganika, leather tanganika, cherry tanganika, tobacco tanganika

cornice *walled frame* BAROCCA

barocca: 90x38 mm telescopica
barocca: 90x38 mm telescopic



capitello *capital* A



capitello *capital* B



capitello *capital* C



finiture: laccati, goffrati, tanganika, tanganika cuoio, tanganika ciliegio, tanganika tabacco
finishes: lacquered, embossed, tanganika, leather tanganika, cherry tanganika, tobacco tanganika

telaio *frame* RADIUS

telaio arrotondato raggio 10mm con doppia fresata per inserimento cornici telescopiche e guarnizione di battuta
ray 10mm frame with double milling for the introduction of telescopic frames and door stop gasket

radius + recta 70x30 mm
radius + curva 80x40 mm
radius + sagoma 75x40 mm



cornice *walled frame* CURVA
cornice *walled frame* RECTA
disponibile con traverso recta
available with recta top rail
cornice *walled frame* SAGOMA
disponibile con traverso recta
available with recta top rail

telaio *frame* SINUO

telaio arrotondato raggio 50mm con doppia fresata per inserimento cornici telescopiche e guarnizione di battuta
ray 50mm frame with double milling for the introduction of telescopic frames and door stop gasket

sinuo + recta 70x30 mm
sinuo + curva 80x40 mm
lineo + sagoma 75x40 mm



cornice *walled fram* RECTA
cornice *walled frame* CURVA
disponibile con traverso recta
available with recta top rail
cornice *walled frame* SAGOMA
disponibile con traverso recta
available with recta top rail

Accessori *Accessories / serrature locks*

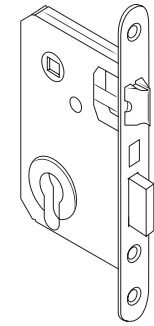

290
serratura yale standard completa
di cilindro da 70 mm
yale lock with cylinder of 70 mm

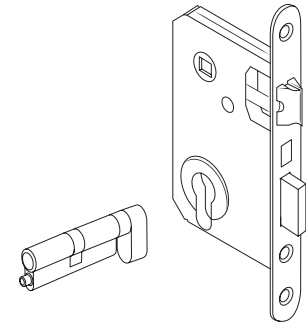

OPERA
serratura antipanico optional
con cilindro mk e segnalatore lib/occ
panic lock optional with cylinder
and signaller free/busy

spioncino *spyhole*

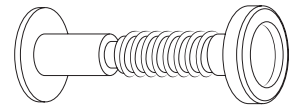

certificato REI
REI certified

griglia *grids*

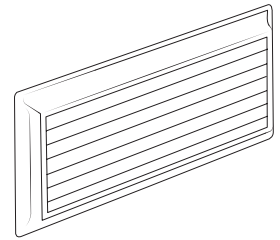

GRIGLIA VENTILATA
VENTILATION GRIDS
certificata REI dimensioni passaggio aria 28x10 cm
REI certified air passage dimension 28x10 cm

maniglie *handles*

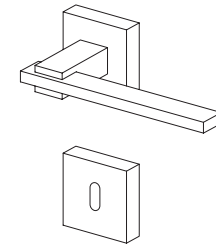

SIRIO
cromo satinato e cromo
lucido/cromo satinato
etched chrome and burnished
chrome/etched chrome

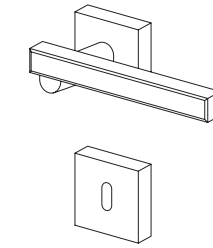

MINIMAL
cromo satinato/cromo lucido
etched chrome/burnished chrome

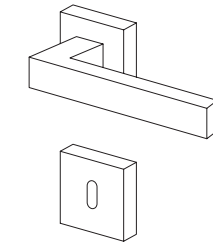

QUADRA
cromo satinato, cromo lucido
e bianco opaco
etched chrome, burnished
and dull-white chrome

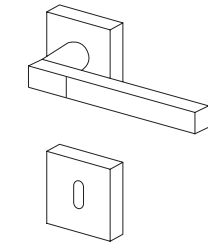

EQUINOX
cromo satinato/cromo lucido
etched chrome/burnished chrome

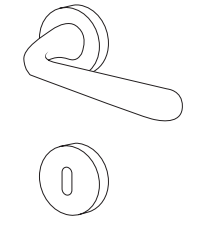

MIRA
cromo satinato, cromo lucido,
ottone lucido, bronzato
etched chrome, burnished chrome,
burnished brass, bronze brass

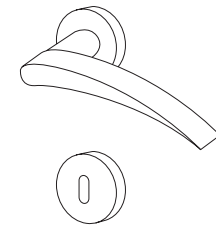

APRI
cromo satinato, cromo lucido
e ottone lucido
etched chrome, burnished chrome
and burnished brass

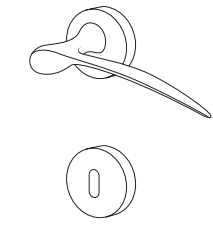

SPIRIT
cromo satinato, cromo lucido
e ottone lucido
etched chrome, burnished chrome
and burnished brass

maniglioni antipanico *panic handles*

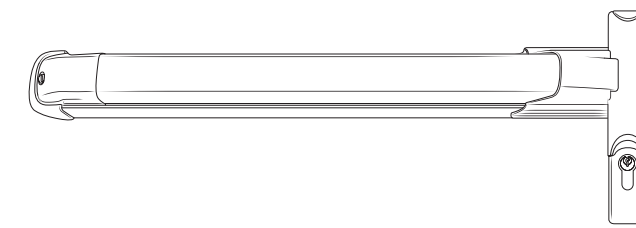

PUSH-BAR
PUSH-BAR

maniglioni *pull handles*

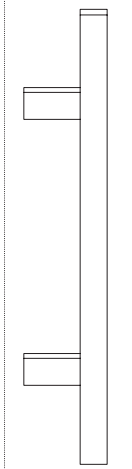

QUADRATO
SQUARE

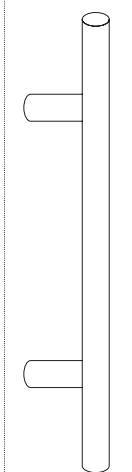

ROTONDO
ROUND

chiudiporta *door closer*

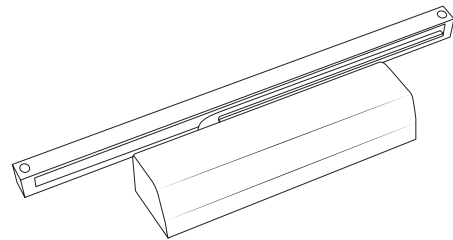

con braccio a slitta
door closer with slide channel

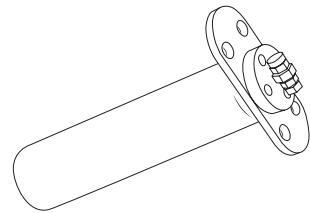

con molla a scomparsa
concealed with spring retractable

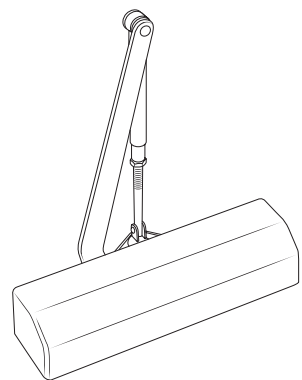

con braccio a V
door closer with scissor arm

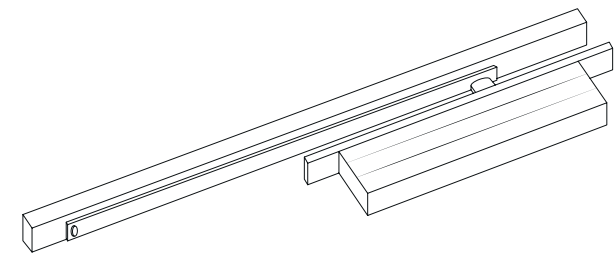

ad incasso
recessed

pomoli *door knobs*

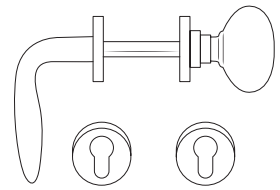

ROTONDO
ROUND

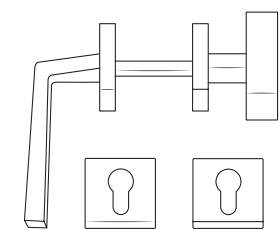

QUADRATO
SQUARE

targhe *plates*



01
in alluminio a disegno
in aluminium on request



02
in alluminio a disegno
in aluminium on request



03
in alluminio a disegno
in aluminium on request



04
in alluminio a disegno
in aluminium on request



STANDARD
STANDARD

Flessya srl

Via dell'Artigianato 13 - 60030 Monte Roberto AN

p.iva 02287520429

tel 0731.70.74.11

fax 0731.70.74.70

www.flessya.it

info@flessya.it

commerciale@flessya.it

amministrazione@flessya.it

Paolo Pantaleoni

area commerciale - commercial area

paolo.pantaleoni@flessya.it

int 0731.70.74.25

Federica Brunori

area commerciale - commercial area

federica.brunori@flessya.it

int 0731.70.74.26

Francesco Fioretti

area commerciale - commercial area

francesco.fioretti@flessya.it

int 0731.70.74.27

Matteo Mancini

area commerciale - commercial area

matteo.mancini@flessya.it

int 0731.70.74.29

Rina Cimarelli

area amministrativa - administration

rina.cimarelli@flessya.it

int 0731.70.74.24

Marco Marchegiani

area amministrativa - administration

marco.marchegiani@flessya.it

int 0731.70.74.22

Diego Bonci

area acquisti - purchase area

diego.bonci@flessya.it

int.0731.70.74.28

Paolo Perticaroli

area produzione - production area

paolo.perticaroli@flessya.it

int 0731.70.74.23

Ireneo Perticaroli

amministratore unico - single administrator

ireneo.perticaroli@flessya.it

int 0731.70.74.21

FLESSYA

R

design:
tangherlini.it

images:
tangherlini.it

FLESSYA srl

Via dell'Artigianato 13
60030 Monte Roberto AN
p.iva 02287520429
tel 0731.70.74.11
fax 0731.70.74.70
www.flessya.it
info@flessya.it



DELUXE SYSTEMS Pte Ltd
National Design Centre
111 Middle Rd #03-01
Singapore 188969

W.A. Phone: **+6582678923**
Mail: **info@ds.asia**
Website: **www.ds.asia**